



RANGEmaster

Built-in Range

Rangemaster's latest collection of appliances that make cooking a pleasure; simple choices that marry innovation with versatility and style with practicality.

The Rangemaster built-in range offers premium cooking and perfected functionality tested to meet the modern home's demands ensuring our products deliver perfect results without compromise.

Beautiful styling, refined finish and a finesse that promises to inspire you in the kitchen.

GET THE *look*



RMB610BL/SS
Single Cavity 10 Function
Touch Control Oven



RMB45SCBL/SS
Compact Premium
Steam Oven



RMB45WDBL/SS
Warming Drawer



RMB60HPEIGL/
60cm 4 Zone
Induction Hob



GEO43TREBF/
Geo 4-in-1 Trend Tap -
Brushed finish



RANGEmaster
Built-in Range

www.builtinrange.co.uk

the Built-in Range

RMB605BL/SS



- Single Cavity
- 5 Functions
- Stainless Steel Rotary Controls

RMB608BL/SS



- Single Cavity
- 8 Functions
- Stainless Steel Rotary Controls

RMB60HPNGFGL/



- 60cm
- 4 Burner Gas on Glass
- Stainless Steel Rotary Controls
- Cast Iron Pan Supports

RMB60HPNGFSS/



- 60cm
- 4 Burner Gas on Steel
- Stainless Steel Rotary Controls
- Cast Iron Pan Supports

RMB610BL/SS



- Single Cavity
- 10 Functions
- Soft Close Door
- Touch Control

RMB610PBL/SS



- Single Cavity
- 10 Functions
- Soft Close Door
- Pyrolytic Oven
- Touch Control

RMB70HPNGFGL/



- 70cm
- 5 Burner Gas on Glass
- Stainless Steel Rotary Controls
- Cast Iron Pan Supports

RMB70HPNGFSS/



- 70cm
- 5 Burner Gas on Steel
- Stainless Steel Rotary Controls
- Cast Iron Pan Supports

RMB7245BL/SS



- Built-under Double
- 4 / 5 Functions
- Steel Rotary Controls

RMB7248BL/SS



- Built-under Double
- 4 / 8 Functions
- Steel Rotary Controls

RMB60HPECGL/



- 60cm
- 4 Zone Ceramic
- Touch Control

RMB60HPEIGL/



- 60cm
- 4 Zone Induction
- Touch Control

RMB9045BL/SS



- 90cm
- 4 / 5 Functions
- Steel Rotary Controls

RMB9048BL/SS



- 90cm
- 4 / 8 Functions
- Steel Rotary Controls

RMB75HPECGL/



- 75cm
- 5 Zone Ceramic
- Touch Control

RMB45MCBL/SS



- 45cm Compact
- Microwave Combi
- Touch Control

RMB45SCBL/SS



- 45cm Compact
- Steam
- Touch Control

RMB45WDBL/SS



- 14cm
- Warming Drawer
- Hot air warming

RMB45SDBL/SS



- 14cm
- Storage Drawer
- 25kg capacity

OVEN FUNCTIONS



LIGHT

Ideal for illumination of the cavity for cleaning, whilst food is cooling or simply to maintain ambient lighting in the kitchen.



DELICATE BAKE

Perfect for pastry dishes such as Quiche or an open tart to ensure a crisp base is achieved whilst cooking the filling.



DEFROST

A safer way to speed up the defrosting process. Using the fan to circulate unheated air around the cavity so you won't accidentally cook your food, like a microwave can.



BROWNING

Great for browning off pasta or dishes that are topped with cheese to create a perfect finish to your dish.



GRILL

Ensures a high direct temperature for meats or where browning of a dish is required.



FAN ASSISTED

Utilising the conventional oven elements alongside the fan, this produces zoned cooking with the hottest zone being featured at the top of the oven.



FANNED GRILL

Enables the door to be closed whilst grilling. This ensures a more consistent result while preventing cooking smells from permeating the room.



DUO

Using the lower element only, this cooking method is often used for slow-cooking casseroles and can also be used to give a crispy base to your pizza.



FANNED

A fan oven draws air from the interior of the oven, heats it up and forces it back into the cavity again. The heat within a fan oven is evenly distributed for multi-level cooking and consistent results.



RAPID COOKING

A fast and intensive cook when you're in a hurry. Use for dishes that aren't temperature sensitive such as ready meals or simply for searing meats.



CONVENTIONAL

This traditional cooking method uses heat sourced from both the top and bottom of the oven, this results in a natural convection process that centres the heat in the top of the oven.



BASE HEAT

Direct heat from the base of the oven; great for baking pastry blind, quiche and any dessert with a pastry base

OVEN FEATURES



LARGE CAPACITY

Large capacity 73L single oven cavities as standard.



SOFT CLOSE DOORS

On both the 10 function single ovens.



PREMIUM REFINEMENT

Steel constructed bar handle and rotary controls.

HIGH SPECIFICATION



10 FUNCTION PYROLYTIC

RMB610PBL/SS

- 10 functions
- Pyrolytic cleaning
- Soft close door
- Stainless Steel bar handle
- 73L large capacity oven
- Quadruple glazed removable door
- TFT touch control
- A rated for energy efficiency
- 24hr Programmable LED display
- 2 shelves
- 1 grill pan
- 2 year warranty



PYROLYTIC CLEANING

For ease of cleaning, the RMB610PBL features pyrolytic cleaning allowing the oven to literally clean itself by carbonising the entire cooking residue to fine ash.



BUILT-IN SINGLE OVENS



10 FUNCTION TOUCH CONTROL

RMB610BL/SS

- 10 Functions
- Soft close door
- Stainless Steel bar handle
- 73L large capacity oven
- Triple glazed removable door
- Touch control
- Easy clean enamel
- A rated for energy efficiency
- 24hr Programmable LED display
- 2 shelves
- 1 grill pan
- 2 year warranty



8 FUNCTION

RMB608BL/SS

- 8 Functions
- Stainless Steel bar handle
- 73L large capacity oven
- Triple glazed removable door
- Stainless Steel rotary control
- Easy clean enamel
- A rated for energy efficiency
- 24hr Programmable LED display
- 2 shelves
- 1 grill pan
- 2 year warranty



5 FUNCTION

RMB605BL/SS

- 5 Functions
- Stainless Steel bar handle
- 73L large capacity oven
- Triple glazed removable door
- Stainless Steel rotary control
- Easy clean enamel
- A rated for energy efficiency
- 24hr Programmable LED display
- 2 shelves
- 1 grill pan
- 2 year warranty



BUILT-UNDER DOUBLE OVENS

BUILT-IN DOUBLE OVENS



4 / 8 FUNCTION

RMB7248BL/SS

- 8 function main cavity
- 4 function second cavity
- Stainless Steel bar handle
- 80L combined capacity 45/35
- Triple glazed removable door
- Stainless Steel rotary control
- A/A rated for energy efficiency
- 24hr Programmable LED display
- Easy clean enamel
- 3 shelves
- 1 grill pan / 1 roasting tray
- 2 year warranty



4 / 8 FUNCTION

RMB9048BL/SS

- 8 function main cavity
- 4 function second cavity
- Stainless Steel bar handle
- 91L combined capacity 56/35
- Triple glazed removable doors
- Stainless Steel rotary control
- A/A rated for energy efficiency
- 24hr Programmable LED display
- Easy clean enamel
- 3 shelves
- 1 grill pan / 1 roasting tray
- 2 year warranty



4 / 5 FUNCTION

RMB7245BL/SS

- 5 function main cavity
- 4 function second cavity
- Stainless Steel bar handle
- 80L combined capacity 45/35
- Triple glazed removable doors
- Stainless Steel rotary control
- A/A rated for energy efficiency
- 24hr Programmable LED display
- Easy clean enamel
- 3 shelves
- 1 grill pan / 1 roasting tray
- 2 year warranty



4 / 5 FUNCTION

RMB9045BL/SS

- 5 function main cavity
- 4 function second cavity
- Stainless Steel bar handle
- 91L combined capacity 56/35
- Triple glazed removable doors
- Stainless Steel rotary control
- A/A rated for energy efficiency
- 24hr Programmable LED display
- Easy clean enamel
- 3 shelves
- 1 grill pan / 1 roasting tray
- 2 year warranty



ACCESSORIES

Single ovens feature 2 shelves and grill pan (with removable handle) whilst the double ovens come with 3 shelves, 1 grill pan (with removable handle) and 1 roasting pan.

PAIR WITH A RANGEMASTER BUILT-IN HOB

Complementary ceramic, gas on stainless, gas on glass and induction hobs will make the perfect partner in your kitchen.



COMPACTS & DRAWERS

HIGH SPECIFICATION



PREMIUM STEAM

RMB45SCBL/SS

- 8 Functions
- Touch control
- A rated for energy efficiency
- White LED display
- Programmable LED display
- 1 perforated tray
- 1 solid tray
- 2 year warranty



MICROWAVE COMBINATION OVEN



RMB45MCBL/SS

- Combination cooking
- 8 Functions
- 6 power levels
- Touch control
- A rated for energy efficiency
- White LED display
- Programmable LED display
- Glass turntable plate
- High wire rack
- 2 year warranty



WARMING DRAWER

RMB45WDBL/SS



- Hot air warming system
- Controllable heat 30° - 60°
- Handle-less touch to open
- Non-slip drawer lining

STORAGE DRAWER

RMB45SDBL/SS



- 25kg capacity
- Handle-less touch to open
- Non-slip drawer lining

GETTING THE MOST FROM STEAM COOKING

Utilising the latest in premium technology, the forced steam system tailors the steam delivery to provide perfect results on any dish. Healthy, easy and flavour packed; cooking with steam is easy. An entire meal can be made in a single cooking process with no taste transfer.



Steam - 40° - 100° heat. An all encompassing function for a variety of uses to provide healthy, flavour packed results



Meat - 80° - 100° heat with 5 auto programmes that ensure a succulent finish to all meat dishes.



Fish - 70° - 100° automatic programmes that ensures fish dishes are prepared to perfection.



Veg - 5 programmable functions to gently cook all types of vegetables and lock in natural flavours and nutrients.



Grill - Ideal to finish your dish with a golden brown glaze.



Pizza - Replicating traditional pizza oven methods, this option provides a refined finish to pizza's, fresh or frozen.



Defrost - Ensures a consistent defrost without the risk of cooking the product through.



De scale - For easy cleaning and maintenance, the de-scale function ensures perfect long term operation.



GAS & ELECTRIC HOBS

GAS

RMB60HPNGFGL/



- 60cm
- 4 burner
- Gas
- Black glass
- Rotary controls
- LPG kit included
- Cast iron pan supports

RMB70HPNGFGL/



- 70cm
- 5 burner
- Gas
- Black glass
- Rotary controls
- LPG kit included
- Cast iron pan supports

RMB60HPNGFSS/



- 60cm
- 4 burner
- Gas
- Stainless Steel
- Rotary controls
- LPG kit included
- Cast iron pan supports

RMB70HPNGFSS/



- 70cm
- 5 burner
- Gas
- Stainless Steel
- Rotary controls
- LPG kit included
- Cast iron pan supports

CERAMIC

RMB60HPECGL/



- 60cm
- 4 Zone
- Fast response
- Touch control
- Hot hob indicator
- Child safety lock

RMB75HPECGL/



- 75cm
- 5 Zone
- Fast response
- Touch control
- Hot hob indicator
- Child safety lock

INDUCTION



INDUCTION

RMB60HPEIGL/

- 4 Zone
- Electric induction
- Fast response
- Touch control
- Hot hob indicator
- Child safety lock



HOODS & SPLASHBACKS

HOODS

ZEST



- Ceiling suspended hood
- 3 speeds plus intensive
- Timer delay setting
- Remote control included
- Re-circulating as standard
- Charcoal and Aluminium filters included
- LED lighting
- 24 hour setting
- 2 year warranty

VESPER



- Ceiling suspended hood
- 'Up and Down' motorised movement
- 3 speeds plus intensive
- Timer delay setting
- Remote control included
- Re-circulating as standard*
- Charcoal and Aluminium filters included
- 24 hour setting
- 2 year warranty

BELLINI



- Energy efficient
- 4 speeds plus intensive
- Touch control with blue display
- Charcoal and Aluminium filters included
- LED lighting
- Brushless Motor
- Timer Delay
- Available as re-circulating and extraction**
- 2 year warranty

60cm CHIMNEY



- Re-circulating as standard
- Charcoal and Aluminium filters included

* Also available as extraction

** Chimney sections can only be fitted in extraction mode not recirculation mode.

HOODS

OPAL



- Available in 60, 90 or 100cm
- 3 speeds plus intensive
- Touch control with blue display
- Dishwasher safe Aluminium filters
- Charcoal and Aluminium filters included
- LED lighting
- Available as re-circulating and extraction**

SPLASHBACKS

BLACK

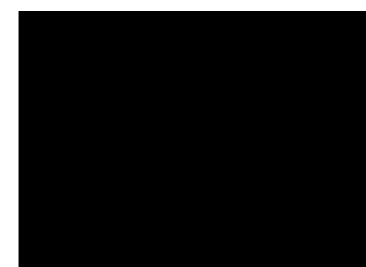

- Available in 60 or 70cm widths
- Stainless Steel construction
- 67cm height

STAINLESS STEEL

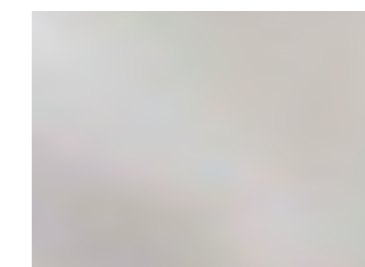

- Available in 60 or 70cm widths
- Stainless Steel construction
- 67cm height



INTEGRATED REFRIGERATORS



70:30

RFXF7030FI/AP

- A+ rated for energy efficiency
- Impressive 232 litre net capacity
- Humidity controlled crisper drawers
- Holiday Mode - ensuring lower energy consumption while you're away
- Super Cool and Super Freeze functions to cool/freeze food quickly to maintain nutrients
- Silver trim on shelving and door furniture
- Reversible hinging
- Four star freezer
- 2 year warranty



50:50

RFXF5050FI/AP

- A+ rated for energy efficiency
- Impressive 241 litre net capacity
- Silver trim on shelving and door furniture
- Humidity controlled drawers
- Totally frost-free throughout the fridge and freezer
- Holiday Mode - ensuring lower energy consumption while you're away
- Super Cool and Super Freeze functions to cool/freeze food quickly to maintain nutrients.
- Reversible hinging
- Four star freezer
- 2 year warranty

UNDER COUNTER FRIDGE

RUCLF540FL/AP

- A+ rated for energy efficiency
- 144 litre net capacity
- Unique strong door shelving with chrome detail
- Modern clear finish on all shelving and drawers
- Reversible hinging
- 2 year warranty



UNDER COUNTER FREEZER

RUCFZ540FL/AP

- A+ rated for energy efficiency
- 97 litre net capacity
- Super freeze functionality
- Modern, clear finish on all drawers
- Four star freezing
- Reversible hinging
- 2 year warranty





INTEGRATED DISHWASHERS



10 PLACE

RDW1045FL/

- Slimline 45cm model
- 10 place setting
- A+ energy efficiency
- 6 washing temperatures
- 8 programmes including: Auto Intensive, Auto Delicate, Rapid, Soak/Prewash & Eco Wash
- Adjustable top level racking
- LCD digital display with silver fascia
- 2 year warranty



12 PLACE

RDW1260FL/

- 5 washing temperatures
- A++ energy efficiency
- 9 programmes including: Auto, Auto Intensive, Auto Delicate, Rapid, Extra Intensive & Eco Wash
- Adjustable top level racking
- Less water consumption, 9 litres per cycle
- LCD digital display with silver fascia
- 2 year warranty



INTEGRATED DISHWASHERS

Our dishwashers come with a host of innovative features, low water consumption, low energy use, simple programming, easily adjustable racking, up-to 19-hour time delay, Auto and Eco wash on both 45cm and 60cm models as well as a choice of top or bottom level half load wash.

LINE DRAWINGS

For full specifications visit www.rangemaster.co.uk

60CM BUILT-IN

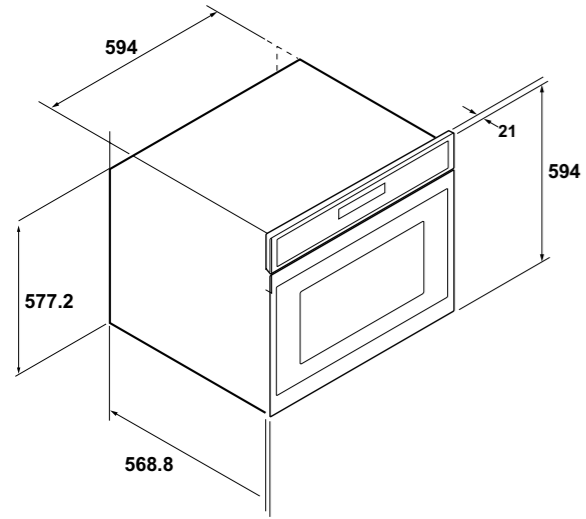

72CM BUILT-IN

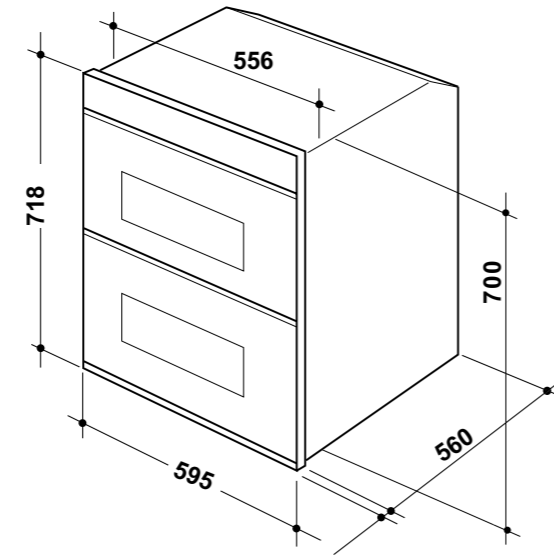

90CM BUILT-IN

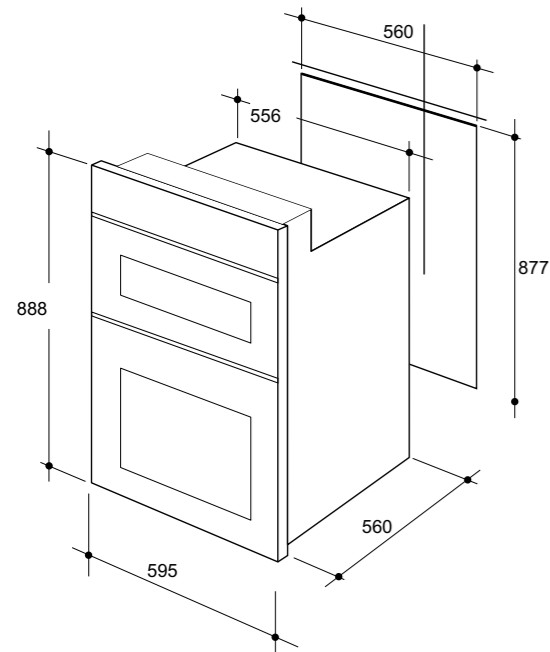

COMPACT STEAM & MICROWAVE

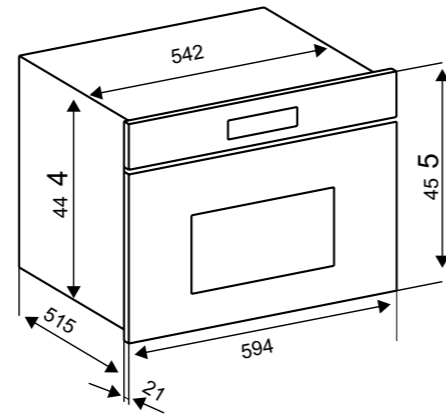

WARMING & STORAGE DRAWERS

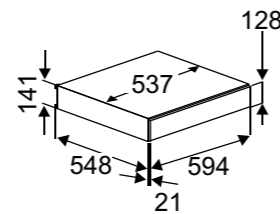

4 ZONE INDUCTION

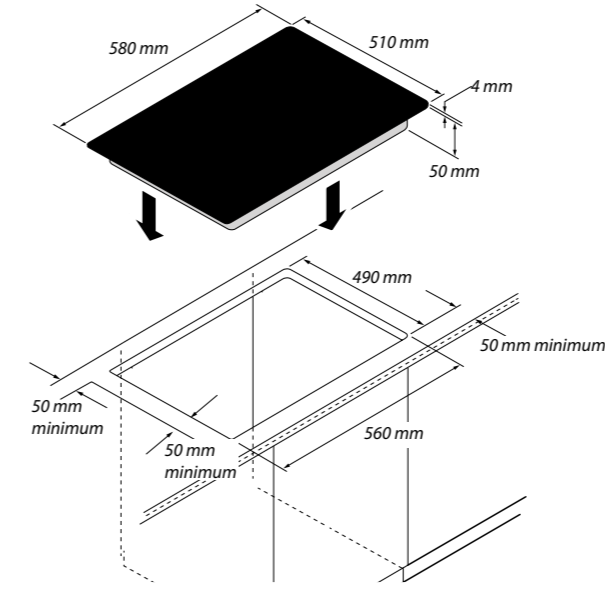

4 BURNER GAS HOB

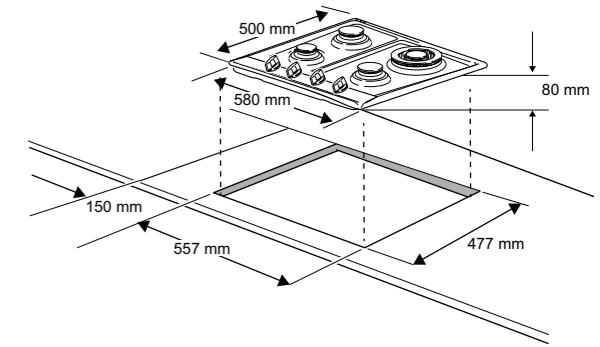

5 BURNER GAS HOB

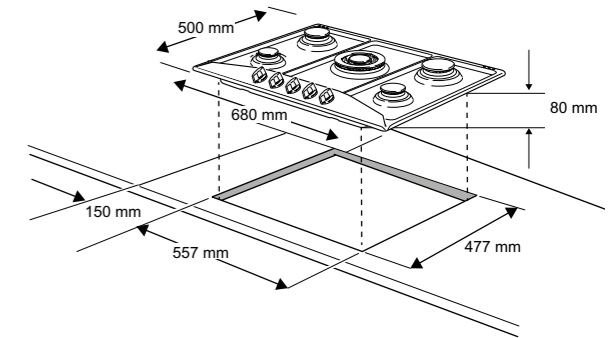

5 ZONE CERAMIC

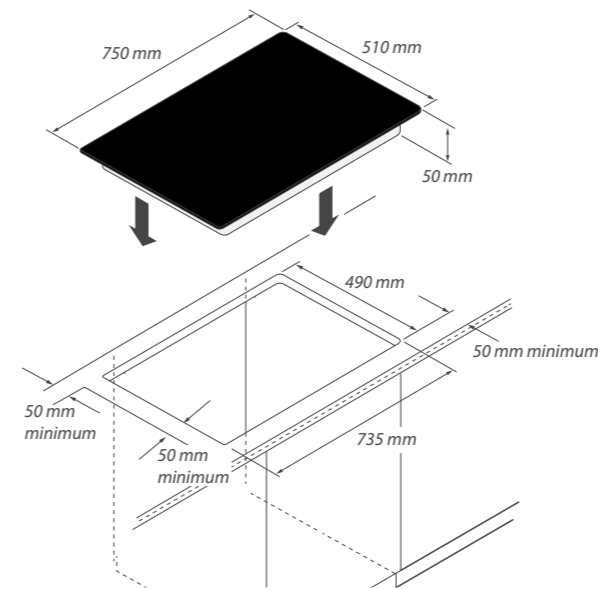

4 ZONE CERAMIC

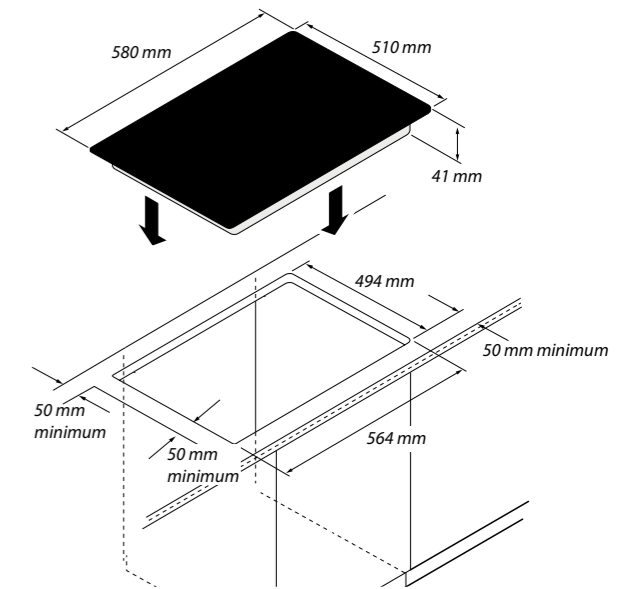

HOODS

	60CM CHIMNEY HOOD			ZEST HOOD				VESPER HOOD				OPAL HOOD				BELLINI HOOD				
WIDTH	598			400				515				598 / 898 / 998				600				
DEPTH	470			400				410				148 - 339				148 - 333				
HEIGHT	725 - 1060			MAX. 1031				MAX. 1305				835 - 1020				710 - 1030				
SPEED	1	2	3	1	2	3	BOOST	1	2	3	BOOST	1	2	3	BOOST	1	2	3	3	BOOST
AIR CAPACITY M3/HOUR*	240	340	470	285	435	540	600	230	345	450	520	300	470	605	690	200	390	500	620	860
AIR CAPACITY M3/HOUR**	250	355	500	295	450	560	630	235	355	460	540	310	490	640	730	210	410	530	660	920
PRESSURE PA	170	220	250	360	450	480	500	360	450	480	500	360	450	480	500	430	440	480	540	630
INPUT W	70	100	145	135	170	215	250	135	170	215	250	135	170	215	250	10	30	55	95	270
NOISE LEVEL DBA***	52	60	66	49	60	65	68	49	60	65	68	52	62	67	70	42	57	62	67	73
DUCTING KIT (MM Ø) ****	150	150	150	150	150	150	150	150	150	150	150	150	150	150	150	150	150	150	150	150
ENERGY RATING	E	E	E	C	C	C	C	D	D	D	D	C	C	C	C	A	A	A	A	A

* As per IEC 61591 when cooker hood is in extraction mode ** As per IEC 61591 when there is 'free air delivery' *** EN 60704-2-13 method
**** Rangemaster recommend 150mm ducting for optimum performance. A 125mm/150mm conversion kit is supplied with the product.

REFRIGERATORS

	50:50	70:30	UNDER COUNTER FRIDGE	UNDER COUNTER FREEZER
DIMENSIONS IN MM				
HEIGHT	1773	1773	818 - 868	818 - 868
WIDTH	555	555	596	596
DEPTH	540	540	550	550
TOTAL GROSS CAPACITY	254 LITRES	266 LITRES	145 LITRES	108 LITRES
TOTAL NET CAPACITY	241 LITRES	232 LITRES	144 LITRES	97 LITRES
REFRIGERATOR CAPACITY	148 LITRES	179 LITRES	144 LITRES	
FREEZER CAPACITY	84 LITRES	62 LITRES		97 LITRES
ENERGY CONSUMPTION / YEAR	313 KWH	300 KWH	123 KWH	192 KWH
SHELVES / DRAWERS	4 FRIDGE SHELVES / 4 FREEZER DRAWS	4 FRIDGE SHELVES / 4 FREEZER DRAWS	3 FRIDGE SHELVES	3 FREEZER DRAWERS / 1 SUPER FREEZE DRAW
SHELVING	GLASS SHELF WITH METAL TRIM	GLASS SHELF WITH METAL TRIM	GLASS SHELF WITH METAL TRIM	
NET WEIGHT	68 KG	69 KG	30 KG	32 KG
REVERSIBLE DOOR	YES	YES	YES	YES
MAX NOISE LEVEL	39 DBA	39 DBA	40 DBA	40 DBA
WARRANTY	2 YEARS	2 YEARS	2 YEARS	2 YEARS
ENERGY RATING	A+ (*/***)	A+ (*/***)	A+	(*/***)

DISHWASHERS

	RDW1260FI/	RDW1045FI/
PRODUCT CODE	RDW1260FI/	RDW1045FI/
PLACE SETTINGS	12	10
ENERGY EFFICIENCY	A++	A+
WASHING EFFICIENCY	A	A
DRYING EFFICIENCY	A	A
ENERGY CONSUMPTION	0.9KW	0.8KW
WATER CONSUMPTION	9 LITRES	12 LITRES
NOISE LEVEL	47 DB(A)	47 DB(A)
NO. OF PROGRAMMES	9	8
DIMENSIONS (H X W X D)(MM)	815-875 x 596 x 550	815-870 x 448x 548
NET WEIGHT	38KG	32KG
INSTALLATION DIMENSIONS (H X W X D)(MM)	820-870 x 600 x 570	815 - 875 x 450 x 570
DIMENSIONS OF REQUIRED DOOR PANEL (MM)	647-717 MAX H	647-717 MAX H
ENERGY CONSUMPTION PER YEAR	258 KW/H	237 KW/H
WATER CONSUMPTION PER YEAR	2520 LITRES	3360 LITRES

E&OE All specifications are subject to change without notice.

Search Rangemaster UK



Introducing

GEO
4-in-1



WATER. EVOLVED

- Consistent 98° hot with no gushing or spitting
 - Dual filtered cold
 - Child safe Hotfob™
- Anti-scale boiler technology
- 0.5 bar operating pressure



Rangemaster's latest addition is GEO; An evolution in 4-in-1 taps delivering domestic hot and cold, filtered cold and 98° hot.

Smart, efficient and safe; GEO offers safe dispensing of 98° water with its child-safe key fob system, smart anti-scale technology for hassle free maintenance and efficiently delivers over 100 cups of perfectly filtered 98° water an hour.

www.geo-taps.co.uk

RANGEMASTER
sinks & taps

RANGEmaster

Built-in Range

RANGEmaster

Clarence Street
Royal Leamington Spa
Warwickshire
CV31 2AD
England

Consumer Services: +44 (0)800 804 6261 or
(0)370 789 5107 from a mobile.
Fax: +44 (0)1926 450526
E-mail: consumers@agarangemaster.co.uk
www.rangemaster.co.uk

For UK Trade Enquiries Tel: +44 (0)115 946 4000
Fax: +44 (0)115 973 6602
E-mail: sales@agarangemaster.co.uk

For ROI Enquiries Tel: 1850 302 502

Rangemaster is a trading name of AGA Rangemaster Limited
Registered in England and Wales. Registration No. 354715
Registered Office: Juno Drive, Leamington Spa, Warwickshire, CV31 3RG

D008331