

Salamander Pumps 

# CT range

of shower, bathroom and whole house pumps



# Salamander Pumps is one of the UK's leading manufacturers of shower and domestic water pumps.

Innovation is used throughout the organisation to create higher quality products and offer outstanding customer service at every step of the journey.

Over the last 5 years we have completely overhauled our product range, taking feedback from installers and householders and using some cutting edge technologies to make Salamander pumps some of the quietest, most compact and reliable pumps on the market.

Whether you need to power just one shower or your whole house, there is a CT Pump to help.

**Contact Pumpwise** for help before, during and after installation on 0191 516 2002 or email [tech@salamanderpumps.co.uk](mailto:tech@salamanderpumps.co.uk)



Excludes CT Bathroom



## CONTENTS

SHOWER PUMPS EXPLAINED 4

TECH<sub>2</sub> OLOGY INSIDE 6

### CT FORCE

The high-quality and robust brass pump range is available as twin or single ended, positive head or universal models. Solid brass impellers and ends, and crossover technology underpins the reliability, quality and performance of this range of pumps.

### CT BATHROOM

With crossover technology allowing for individual outlet operation, a universal option for negative head installations and reduced noise CT Bathroom is the pump of choice for all bathroom applications.

### CT XTRA

The CT Xtra range raises the bar for all other 'entry level' shower pumps to follow. This range of single and twin ended shower pumps will quietly and efficiently boost hot and cold water supplies.

### TECHNICAL

Range comparison, dimensions, flow curves, specification and typical installation diagrams.

# SHOWER PUMPS EXPLAINED

## CONTINUOUS RATING

All Salamander pumps are continuously rated. A pump that is continuously rated, can effectively run for as long as the user chooses, without the need for the pump to shut down, to allow the pump to cool. With a large family in a household this is particularly important, many competitor pumps are not continuously rated, and will automatically shut off for 20 to 45 minutes to allow the pump to cool.

## TWIN ENDED

These pumps pump both hot and cold water supplies with one end for hot water and the other for cold. Each end then goes on to supply the outlet, which is most commonly a shower valve.

## SINGLE ENDED

These pumps operate with a single impeller to pump either cold, hot or blended water.

Typically, single ended pumps can be used to supply electric showers, taps, combination boilers, unvented cylinders or washing machines, but all of which must be supplied via a header tank to the pump.

## WARRANTIES

The CT Xtra and CT Bathroom ranges come with a 3 year warranty. The CT Force range comes with a 5 year warranty.

The standard warranty period of the CT Xtra and CT Bathroom ranges can be extended by a further 2 years at an additional charge. Contact Salamander Pumps on 0191 516 2002 for further information.

## POSITIVE HEAD SYSTEMS

Several different plumbing systems are used in UK homes, the most common of which is a gravity-fed system as shown in the diagram below. In these types of systems there is usually a cold water cistern in the loft with a hot water tank below it, probably in an airing cupboard. If your shower or outlets are not forceful enough due to insufficient water pressure, this can be easily remedied with the installation of a pump.

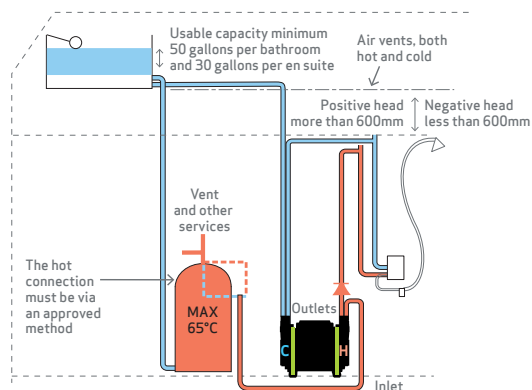

## Negative head

When the distance between the cold water storage tank and the shower head (or the highest point in the system after the pump) is 600 mm or less then the system is negative head. Also if the natural flow is poor or less than 4 litres per minute of combined hot and cold it is possible a universal pump may be required.

## NEGATIVE HEAD SYSTEMS (GRAVITY-FED)

If any point in the system after the pump goes within 600mm of the base of the cold water tank or above it, including pipework, this can cause a negative head system as there would be poor natural flow to the outlets. Negative head pumps may also be required where pumped hot meets mains cold water, where two pumps are fitted individually on hot and cold sides of the system, electric showers, washing machines and dishwashers. Some restrictive outlets such as body jets may also require a negative head pump.

# TECH<sub>2</sub>OLOGY INSIDE

We continually strive to improve our pumps and have introduced some clever technology to do this. (CT) indicates the technology in the CT ranges.



## **CROSSOVER™** (CT Force and Bathroom)

An innovatively designed bypass tube found in Right Pumps. This diverts water to the end of the pump that isn't pumping water. Typically this happens when the user switches off one tap when filling a bath or basin. The Crossover stops the overheating/expansion of the side of the pump that isn't seeing water.



## **SOLID STATE SWITCHING™** (CT)

An electronic switch which activates the pump. The switch has no moving parts, so this improves reliability, sensitivity, and extends product life.



## **DYNAMIC RESPONSE SYSTEM™ (DRS)**

DRS is the pumps ability to react to a variation in pressure or flow. E.g. if the flow increases then the DRS will send a message to the motor to slow down, meaning that the pump maintains a consistent water output.



## **INTERROGAI™**

Technology within the pump that monitors usage e.g. how many times it has been switched on/off or how long it has been running for. It aids in the diagnosis of issues.



## **DYNAMIC PUMP CONTROL™**

The intelligent electronics that run the motor at a given speed. This makes the pump more energy efficient, responsive and longer lasting.



## **NOISE/VIBRATION REDUCTION™** (CT)

Product design innovation has been used to reduce the noise and vibrations in a shower pump, including noise reducing feet and specially selected materials which dampen the vibration of the motor.



## **BRUSHLESS MOTORS™**

These motors allow for variable speed control, intelligently using the correct amount of electricity required to drive the pump. They have NO contacting parts which make them less likely to wear out and this combined with tighter tolerances also reduces friction and noise.



## **ADVANCED MOTOR DRIVE™**

Used with brushless motors, this technology controls the spinning and speed of the motor using feedback from other parts of the pump. This allows for an instant reaction, seamless performance and energy efficiency.



## **MOTOR PUMP INTEGRATION™** (CT)

The innovative product design building the motor into the pump impeller housing to allow for an extremely compact product. The design also means that the cold waterway helps cool the motor, thereby improving efficiency and product life.



## **ANTI STICTION PROTECTION (ASP)™**

A film of water across the seals acts a lubricant and prevents them from sticking, however if a pump is not operated for a length of time (a week or so or more) the film of water dries out and this can mean the pump fails to start. Our pumps have electronics which detect when a pump hasn't been used for 48 hours which turn the pump on momentarily to refresh the film of water and prevent the pump from sticking.

# CT FORCE (UNIVERSAL)

Universal (negative head) brass regenerative pumps, ideal for delivering a real boost to low water pressure systems.



Twin ended only



Efficient water way design, solid brass impellers and robust brass ends make this range of pumps powerful and robust. Crossover technology, which is in all of the CT Force twin ended pumps, means they can be used for multiple or single outlet use.

Innovative engineering of the product has led to the range being awarded the Quiet Mark, and independent testing has shown the CT Force 15PT/TU to be the quietest twin ended brass pump on the market.\*

### Quiet. Powerful. Patented technology.

Pump	Application	Bar	dBA
CT Force 15TU	Twin end, universal head shower pump	1.5	48
CT Force 20TU	Twin end, universal bathroom pump	2.0	54
CT Force 30TU	Twin end, universal house pump	3.0	52.5
CT Force 20SU	Single end, universal head bathroom pump	2.0	49
CT Force 30SU	Single end, universal house pump	3.0	42

\*Independently tested, contact us for details.

# CT FORCE (POSITIVE HEAD)



Robust, brass regenerative pumps for boosting pressure to single outlets, bathrooms or the whole house.



Twin ended only

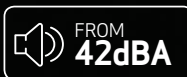

Quiet, compact and robust, this range of brass pumps can deliver a boost to hot and/or cold supplies to thermostatic or manual mixer valves, supplying a wide range of shower types, shower heads, individual taps, cisterns and other appliances, and whole house boosting applications.

The CT Force range is patent protected, and has received the Quiet Mark for being some of the quietest brass shower pumps on the market.\*

### Quiet. Powerful. Patented technology.

Pump	Application	Bar	dBA
CT Force 15PT	Twin end, positive head bathroom pump	1.5	48
CT Force 20PT	Twin end, positive head bathroom pump	2.0	54
CT Force 30PT	Twin end, positive head house pump	3.0	52.5
CT Force 20PS	Single end, positive head bathroom pump	2.0	49
CT Force 30PS	Single end, positive head house pump	3.0	42

\*Independently tested, contact us for details.

# CT BATHROOM (UNIVERSAL)

Specifically designed to meet the increased demands for water supply within your en-suite, bathroom or utility room.



FROM  
**53.5dBA**



The CT Bathroom Universal range has been specifically designed to deliver the pressure and performance needed to boost water supplies to a bathroom, en-suite or utility room. Innovative and patent protected, this range of pumps is also compact and powerful.

Suitable across a wide range of shower types and heads, single and mixer taps, these pumps will also refill your toilet cistern in double quick time.

**Quiet. Powerful. Patented technology.**

Pump	Application	Bar
CT 60BU	Twin end, universal bathroom pump	1.8
CT 80BU	Twin end, universal bathroom pump	2.6

\*Independently tested, contact us for details.

# CT BATHROOM (POSITIVE HEAD)



The pump designed for bathrooms.



With their advanced design features the CT Bathroom positive head range of pumps will efficiently boost the hot and/or cold water supplies to shower, baths, basins and toilets.

CT Bathroom is the pump of choice for all bathroom applications.

**Quiet. Powerful. Patented technology.**

Pump	Application	Bar
CT 60B	Twin end, positive head bathroom pump	1.8
CT 80B	Twin end, positive head bathroom pump	2.6

\*Independently tested, contact us for details.



# CT XTRA

The hard working,  
affordable pump.



FROM  
**44.5dBA**



CT Xtra is Salamander's biggest selling range of shower pumps and probably the biggest selling range of shower pumps in the UK.

Compact in size, quiet in operation and containing patented technology this pump provides excellent value for money.

Awarded the Quiet Mark, this range of positive head, regenerative pumps are some of the quietest plastic, regenerative pumps on the market.\*

### Quiet. Powerful. Patented technology.

Pump	Application	Bar	dBA
CT 50/50+ Xtra	Twin end, positive head shower pump	1.5	52.5
CT 75/75+ Xtra	Twin end, positive shower pump	2.0	53.5
CT 55/55+ Xtra	Single end, positive head pump	1.5	44.5
CT 85/85+ Xtra	Single end, positive head pump	2.2	52

\*Independently tested, contact us for details.

**CT FORCE**

**PATENTS**  
GB2465392B  
Integrated volute

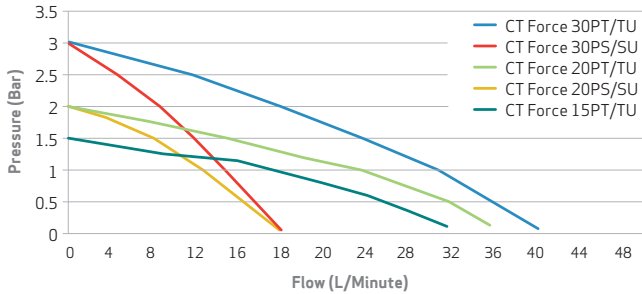
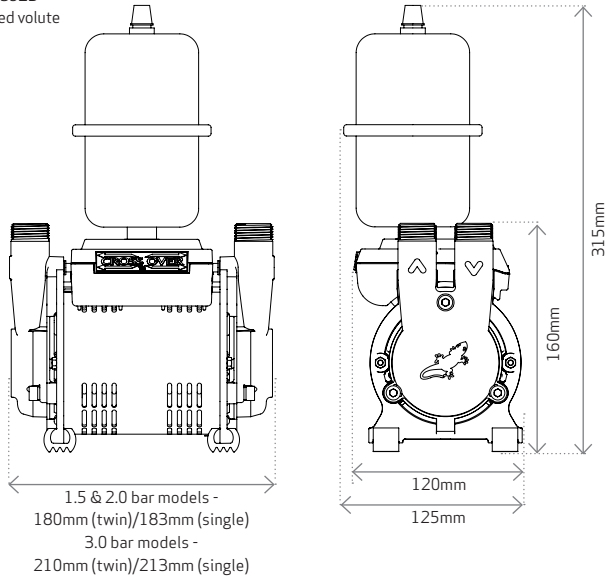

**CT BATHROOM**

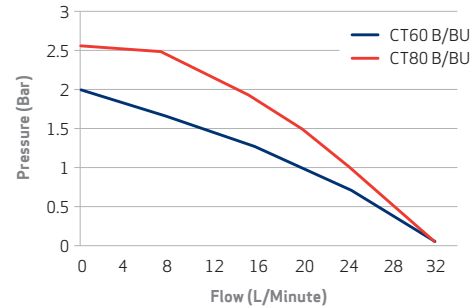
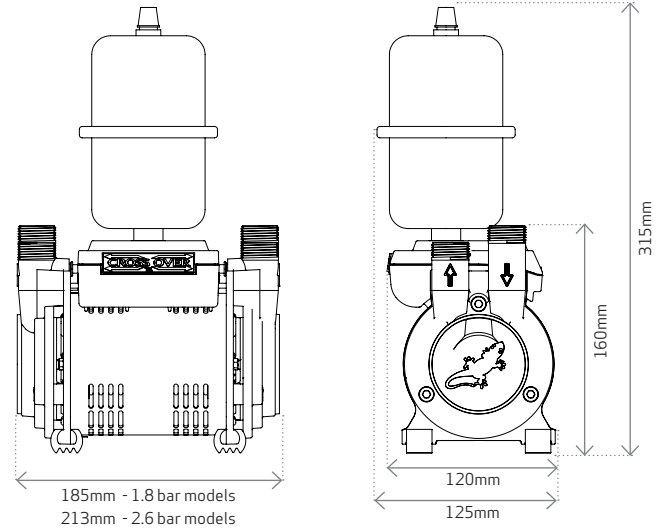

**PATENTS**  
GB2465392B  
Integrated volute

## CT XTRA

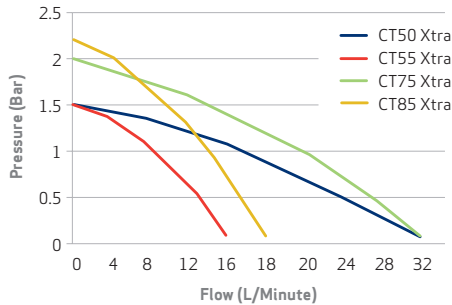
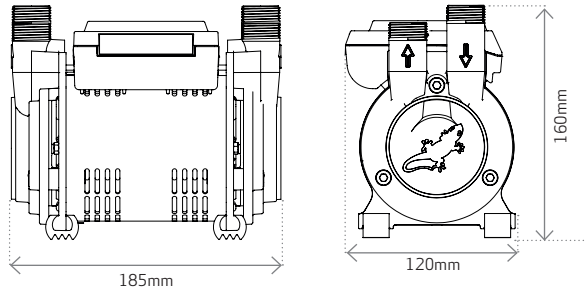

## NOISE

Noise is one of the deciding factors when choosing a shower pump, which is why the CT Range of pumps have been engineered so that they are amongst the quietest on the market.

All of our pumps have been independently tested against our competitor's products and we can now say that we have some of the quietest pumps on the market.



CT Xtra and CT Force ranges have also been awarded the Quiet Mark, an international approval award programme associated with the UK Noise Abatement Society charitable foundation. Quiet Mark encourages companies worldwide to prioritise noise reduction within the design of everyday machines and appliances, and find solutions to noise problems.

For further information on noise and individual dBA ratings visit [salamanderpumps.co.uk](http://salamanderpumps.co.uk)

CT FORCE		TWIN			SINGLE	
		CT FORCE 15 PT/TU	CT FORCE 20 PT/TU	CT FORCE 30 PT/TU	CT FORCE 20 PS/SU	CT FORCE 30 PS/SU
FEATURES	Pump type	Regenerative				
	Mechanical seal	Nitrile / Carbon / Ceramic				
	Anti-vibration feet	✓	✓	✓	✓	✓
	Inlet isolator(s)	✓	✓	✓	✓	✓
	Flexible hoses	4	4	4	2	2
PERFORMANCE	Pressure @ 16lpm (8lpm for singles)	1.1	1.5	2.2	1.5	2.1
	Pressure @ 8lpm (4lpm for singles)	1.3	1.8	2.6	1.8	2.6
	Pressure @ closed head	1.5	2.0	3.0	2.0	3.0
	Maximum water temperature	65°C				
	Pressure vessel air pre-charge	22 psi	28 psi	32 psi	28 psi	32 psi
CONNECTIONS	Pump connections	3/4" BSP				
	Flexible hoses UK model	3/4"	Female x 22mm Push-Fit x 280mm long, isolating valves on all hoses			
	Flexible hoses ROI model	3/4"	Female x 21mm Push-Fit x 280mm long, isolating valves on all hoses			
MOTOR	Type	A.C Induction Motor				
	Duty rating	Continuously Rated				
ELECTRICAL	Power supply	230 V				
	Current (full load) - amps	2.0	2.2	2.9	1.3	1.9
	Power consumption - watts	457	531	690	304	410
	Fuse rating - amps	3				
	Power cable (pre-wired)	1.5 metres				
PHYSICAL	Enclosure protection (IP rating)	IPX2				
	Weight (excluding hoses)	5.0/5.5 kg	5.0/5.6 kg	6.2/6.8 kg	4.3/5.0 kg	5.6/6.2 kg

CT BATHROOM		TWIN	
		CT BATHROOM 60B/BU	CT BATHROOM 80B/BU
FEATURES	Pump type	Regenerative	
	Mechanical seal	Nitrile / Carbon / Ceramic	
	Anti-vibration feet	✓	✓
	Inlet isolator(s)	✓	✓
	Flexible hoses	4	4
PERFORMANCE	Pressure @ 16lpm (8lpm for singles)	1.2	1.8
	Pressure @ 8lpm (4lpm for singles)	1.6	2.4
	Pressure @ closed head	1.8	2.6
	Maximum water temperature	65°C	
	Pressure vessel air pre-charge	28 psi	
CONNECTIONS	Pump connections	3/4" BSP	
	Flexible hoses UK model	3/4" Female x 15mm Push-Fit isolating valves	3/4" Female x 22mm Push-Fit x 280mm long, isolating valves on all hoses
	Flexible hoses ROI model	3/4" Female x 21mm Push-Fit x 280mm long, isolating valves on all hoses	
MOTOR	Type	A.C Induction Motor	
	Duty rating	Continuously Rated	
ELECTRICAL	Power supply	230 V	
	Current (full load) - amps	2.0	2.2
	Power consumption - watts	455	484
	Fuse rating - amps	3	
	Power cable (pre-wired)	1.5 metres	
PHYSICAL	Enclosure protection (IP rating)	IPX2	
	Weight (excluding hoses)	4.0/4.6 kg	5.2/5.8 kg

**CT XTRA**

		TWIN		SINGLE	
		CT50 XTRA / 50+ XTRA	CT75 XTRA / 75+ XTRA	CT55 XTRA / 55+ XTRA	CT85 XTRA / 85+ XTRA
<b>FEATURES</b>	Pump type	Regenerative			
	Mechanical seal	Nitrile / Carbon / Ceramic			
	Anti-vibration feet	✓	✓	✓	✓
	Inlet isolator(s) - only on '+' models	✓	✓	✓	✓
	Flexible hoses	4	4	2	2
<b>PERFORMANCE</b>	Pressure @ 16lpm (8lpm for singles)	1.0	1.3	1.1	1.7
	Pressure @ 8lpm (4lpm for singles)	1.3	1.7	1.4	2.0
	Pressure @ closed head	1.5	2.0	1.5	2.2
	Maximum water temperature	65°C			
<b>CONNECTIONS</b>	Pump connections	3/4" BSP			
	Flexible hoses UK model	3/4" Female x 15mm Push-Fit x 195mm long			
	Flexible hoses ROI model	3/4" Female x 21mm Push-Fit x 195mm long			
<b>MOTOR</b>	Type	A.C Induction Motor			
	Duty rating	Continuously Rated			
<b>ELECTRICAL</b>	Power supply	230 V			
	Current (full load) - amps	2.0	2.1	1.3	1.1
	Power consumption - watts	455	484	273	246
	Fuse rating - amps	3			
	Power cable (pre-wired)	1.5 metres			
<b>PHYSICAL</b>	Enclosure protection (IP rating)	IPX2			
	Weight (excluding hoses)	3.6 kg	4.0 kg	3.5 kg	3.9 kg

CT XTRA			CT FORCE																					
SINGLE	TWIN						TWIN						SINGLE						TWIN					
	CT55	CT55+	CT85	CT85+	CT50	CT50+	CT75	CT75+	CT60B	CT60BU	CT80B	CT80BU	CT20PS	CT20SU	CT30PS	CT30SU	CT15TU	CT15PT	CT20PT	CT20TU	CT30PT	CT30TU		

**PERFORMANCE**

Bar Rating/Closed Head	1.5	1.5	2.5	2.5	1.5	1.5	2.0	2.0	1.8	1.8	2.6	2.6	2.0	2.0	3.0	3.0	1.5	1.5	2.0	2.0	3.0	3.0
------------------------	-----	-----	-----	-----	-----	-----	-----	-----	-----	-----	-----	-----	-----	-----	-----	-----	-----	-----	-----	-----	-----	-----

**PUMP**

Positive Head	•	•	•	•	•	•	•	•	•	•	•	•	•	•	•	•	•	•	•	•	•	•
Universal/Negative Head								•			•		•			•						

**FUNCTION**

SHOWER ONLY				•				•														
WHOLE HOUSE								•														
Individual Taps/Outlets	•		•					•														
Combi Boiler												•										
Instant Electric Shower									•													
Washing Machine / Dishwasher									•													
Conventional Shower				•																		
Victorian Can Shower Head										•												
Multi-Function Shower											•											
Body Jets (4max)																						
Toilets	•		•																			
Washbasins	•		•																			

**CONNECTION SIZE / TYPE**

HOSE	Pushfit (mm)	15	15	15	22	22	22	22	22	22	22	22	22	22	22	22	22	22	22	22	22	22
ISOLATORS	Inlet	•			•			•			•											
	Outlet																					

**WARRANTY**

As standard*	3 years	3 years	3 years	3 years	5 years	5 years	5 years	5 years	5 years	5 years	5 years	5 years	5 years	5 years	5 years	5 years	5 years	5 years	5 years	5 years	5 years	5 years
--------------	---------	---------	---------	---------	---------	---------	---------	---------	---------	---------	---------	---------	---------	---------	---------	---------	---------	---------	---------	---------	---------	---------

\* If supplying a mixer shower/tap with cold mains water, a single ended, negative head pump, that matches the mains pressure as close as possible should be used for the gravity hot water. Please note - some positive, single ended pumps may need to be converted to negative head in certain installations. For advice please call Pumpwise on 0191 516 2002.

## POSITIVE HEAD SYSTEM

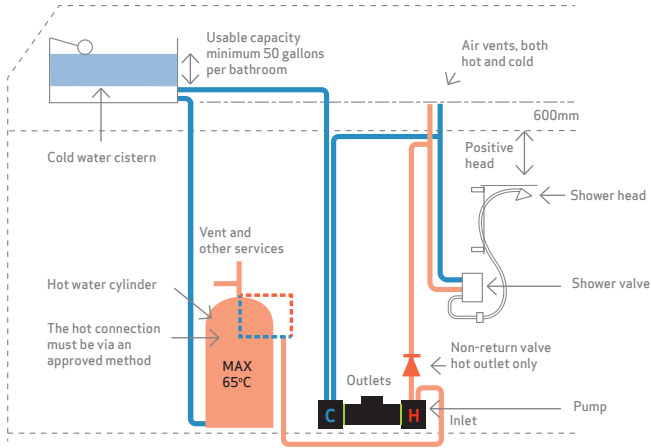

CT pump range twin ended positive head with up and over pipework and natural flow of 1 Litre/min per side.

## NEGATIVE HEAD (UNIVERSAL) SYSTEM

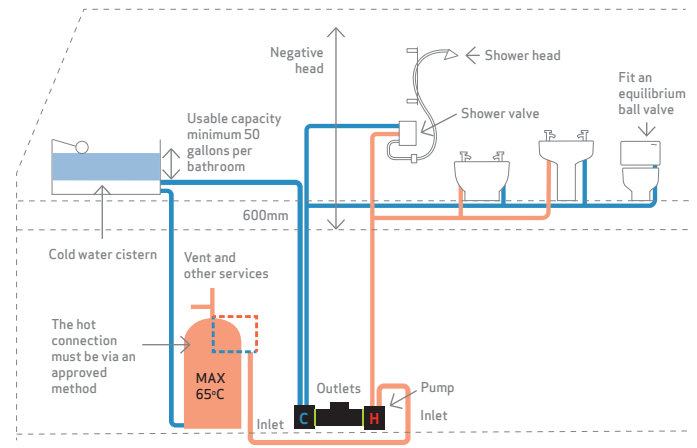

CT pump range twin ended universal to a bathroom in a loft conversion.



Get in touch,  
we're here to help  
call us on  
0191 516 2002

Unit 2c Colima Avenue  
Enterprise Park West  
Sunderland, SR5 3XE



[salamanderpumps.co.uk](http://salamanderpumps.co.uk)

